

July 3, 2026

The University of Electro-Communications  
Lightera Japan Co., Ltd.  
Keio University

## World's First Demonstration of High-Power Optical Signal Transmission Exceeding 10 W in a Wavelength-Multiplexed PON System Using Hollow-Core Fibers

**~Applications of next-generation optical access for ultra-high-branch PON transmission and optical fiber power supply~**

As part of the “Research and Development Project of Advanced Optical Transmission Technology Contributing to a Green Society (JPMI00316)” commissioned by the Ministry of Internal Affairs and Communications, a research group consisting of the University of Electro-Communications, Lightera Japan Co., Ltd., and Keio University, has developed a wavelength-multiplexing PON system [\*1] using a hollow-core fiber [\*2] developed by the Lightera Group [\*3], and has succeeded in transmitting high-power optical signals with an optical fiber input power exceeding 10 W.

It is known that hollow-core fibers exhibit nonlinear effect [\*4] of about 1/1000 compared to conventional silica core optical fibers, but this is the world's first time to achieve high-quality, high-power transmission using actual communication optical signals exceeding 10 W.

### [Development Background]

In wireless systems represented by fifth-generation mobile communication systems (5G) [\*5], with the increasing frequency of wireless signals, numerous wireless base stations [\*6] for mobile communications and IoT (Internet of Things) have been required.

Therefore, applying PON systems, which are currently used for subscriber-based optical networks, is being considered. By combining wavelength division multiplexing [\*7], even larger capacity communications are expected.

Furthermore, by utilizing optical fiber lines, there is growing anticipation for realizing optical fiber power supply [\*8] aiming at ensuring the availability of wireless base stations during disasters and reducing the need for conventional power supply.

In downlink transmission of PON systems, increasing the power of optical signals for communication enables communication to more wireless base stations. However, in silica core optical fibers, which are currently the most widely used, nonlinear effects occur in the core and greatly limit the optical signal power for communication.

If the optical power that can be transmitted by optical fiber can be dramatically improved, it will be possible to transmit not only signals for communication but also light energy, and to supply power to wireless base stations, thereby improving their availability during disasters.

[Development Details]

In this study, we newly introduced hollow-core fiber between the OLT and splitter of the PON system, and by multiplexing four wavelengths of optical signals modulated by the 5G NR signal at a carrier frequency of 28 GHz [\*9], which is the 5G standard, we have successfully greatly suppressed various types of nonlinear effects, which are easily generated in conventional silica core optical fibers, and achieved high-quality, high-power transmission exceeding 10 W. This indicates that more than 4,096 branches would be possible for PON systems where the optical transmissions are shared by many subscribers.

[Future Expectations]

In this experiment, four wavelengths were used for communication. We plan to build a PON system for mobile communication and IoT that enables communication with more wireless base stations by multiplexing more wavelengths over a wider wavelength range.

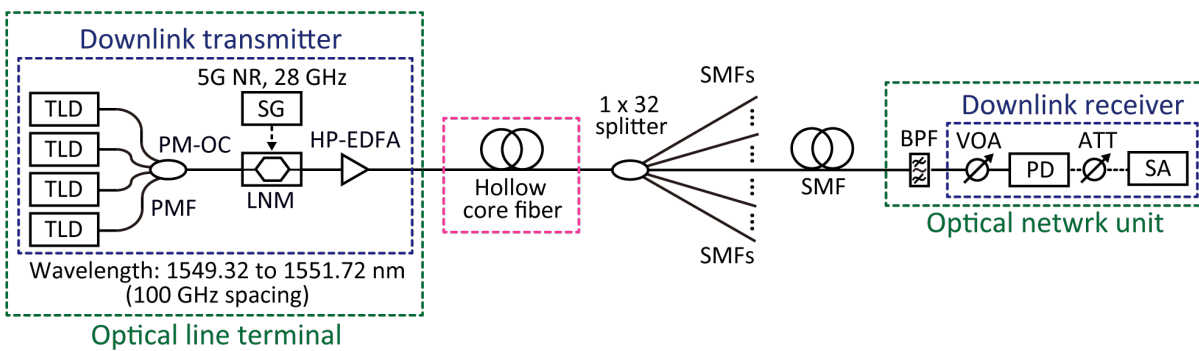

Experimental configuration of high-power PON systems

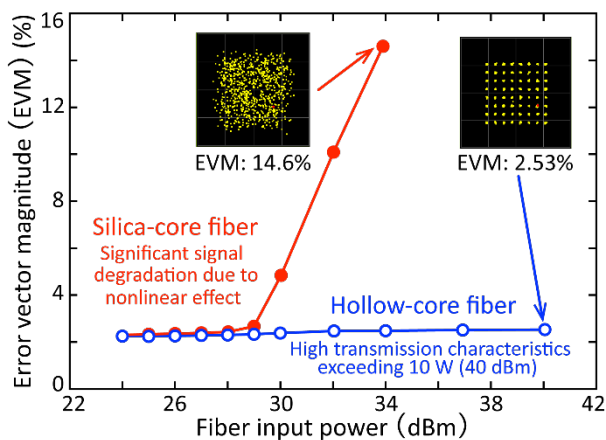
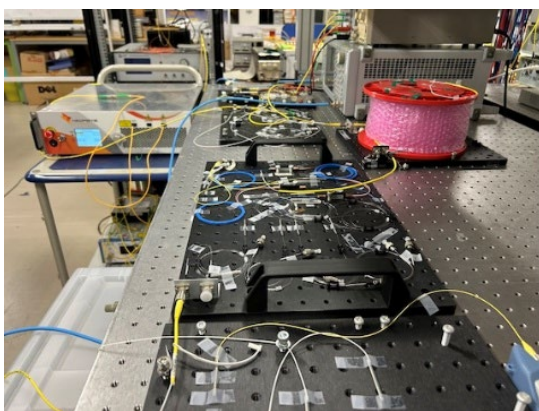

(Left) Experimental configuration and (Right) EVM (transmission characteristics) relative to optical fiber input power

The content developed this time is scheduled to be published in the August 2026 issue of the Journal of Optical Communications and Networking, published by IEEE and Optica Publishing Group.

[Glossary]

[\*1] PON System: PON stands for Passive Optical Network. This is a method in which a single fiber optic line is shared by multiple wireless base stations using passive branching like splitters. The station-side device of PON is called the OLT (Optical Line Terminal), and the subscriber-side device is called the ONU (Optical Network Unit).

[\*2] Hollow-Core Fiber (HCF): A hollow center (core) of the fiber transmits the optical signal through air. Compared to conventional optical fibers, signal degradation can be significantly reduced, making it suitable for low-latency transmission. The transmission delay is approximately two-thirds that of single-mode fiber, and the nonlinearity is as low as one-thousandth.

[\*3] Lightera Group: The global organization for the Furukawa Electric Group's optical solutions business, headquartered in Norcross, Georgia, U.S.A.

[\*4] Nonlinear effect: In optical fiber communications, a phenomenon in which the waveform of an optical signal is distorted when the power of the transmitted light is increased above a certain level.

[\*5] 5th Generation Mobile Communication System (5G): Next-Generation Mobile Communication System enabling "Ultra-High Speed (Maximum Transmission Speed 10Gbps)", "Massive Connections (1 million units/km<sup>2</sup>)", and "ultra-low latency (about 1 millisecond)", simultaneously. It can wirelessly connect all kinds of devices around us, including home appliances, cars, and robots.

[\*6] Wireless base station: Connected to a central station, it transmits and receives information to and from mobile communication terminals. There are wireless base stations for mobile communications, as well as wireless base stations for IoT, which is relatively low power consumption.

[\*7] Wavelength Division Multiplex Transmission: A transmission technology that multiplexes optical signals with different wavelengths on a single optical fiber. By multiplexing over a wider wavelength range and at high density, it is possible to multiplex more wavelengths.

[\*8] Optical fiber power supply: A system that transmits light through the optical fiber not as a signal but as energy and drives remote equipment with the energy converted to electrical power

on the receiving side. Compared to conventional metal wires, it offers unique features, such as excellent corrosion resistance and is less susceptible to electromagnetic interference.

[\*9] 5G NR signal: A radio signal newly developed for 5G wireless transmission. Broadly speaking, it operates in two frequency ranges, but in this study, the 28 GHz radio frequency, included in the higher frequency band, is used.

[Contact Information for This News Release]

University of Electro-Communications,  
General Affairs Planning Division, Public Relations Section  
TEL:042-443-5019 FAX: 042-443-5887  
E-mail: [kouhou-k@office.uec.ac.jp](mailto:kouhou-k@office.uec.ac.jp)

Lightera Japan Co., Ltd.  
Strategy&Planning: [CONTACT](#)

Keio University, Office of Communications and Public Relations  
TEL: 03-5427-1541 FAX: 03-5441-7640  
E-mail: [m-pr@adst.keio.ac.jp](mailto:m-pr@adst.keio.ac.jp)

[Contact Information for Research Content]

University of Electro-Communications,  
Graduate School of Information Science and Engineering,  
Department of Information and Network Engineering  
Professor Motoharu Matsuura  
TEL:042-443-5766  
E-mail: [m.matsuura@uec.ac.jp](mailto:m.matsuura@uec.ac.jp)

Lightera Japan Co., Ltd.  
R&D Department: [CONTACT](#)

Keio Future Photonic Network Open Lab  
Professor Naoaki Yamanaka, Hiroyuki Tsuda, Satoru Okamoto  
E-mail: [yamanaka@keio.jp](mailto:yamanaka@keio.jp)  
Web site: <https://pilab.jp/OpenLab/>